

D-Link DSS-8+

8-port 10/100 Ethernet Switch

Manual

Rev. 12224

D-Link
Building Networks for People

Ver.1.01

TABLE OF CONTENTS

ABOUT THIS GUIDE	1
PURPOSE	1
INTRODUCTION	2
FAST ETHERNET TECHNOLOGY	2
SWITCHING TECHNOLOGY	2
FEATURES.....	4
UNPACKING AND SETUP	6
UNPACKING	6
SETUP.....	6
IDENTIFYING EXTERNAL COMPONENTS	7
FRONT PANEL	7
LED INDICATORS	7
REAR PANEL	8
CONNECTING THE SWITCH	9
COMPUTER TO DSS-8+.....	9
HUB TO DSS-8+.....	9
DSS-8+ TO OTHER DEVICES	9
PORT SPEED & DUPLEX MODE	10
MOUNTING THE SWITCH ON A WALL	11
TECHNICAL SPECIFICATIONS	12
RJ-45 PIN SPECIFICATION	14
WARRANTY.....	15
TECHNICAL SUPPORT	20

ABOUT THIS GUIDE

Congratulations on your purchase of the DSS-8+ Switch. This device integrates 100Mbps Fast Ethernet and 10Mbps Ethernet network capabilities into one high-performance, easy-to-use solution.

Purpose

This manual will familiarize you with the DSS-8+ Switch and guide you through the installation process.

Conventions

For simplicity, this documentation uses the term “Switch” (first letter upper case) to refer to the DSS-8+ Ethernet Switch, and “switch” (first letter lower case) to refer to other Ethernet switches.

INTRODUCTION

Fast Ethernet Technology

The growing importance of LANs and the increasing complexity of desktop computing applications are fueling the need for high performance networks. 100BASE-T (Fast Ethernet) provides a cost-effective and high-performance solution for small workgroups, SMBs (*Small to Medium Businesses*), and any network supporting bandwidth-intensive applications. Fast Ethernet technology operates at 10 times the speed of traditional Ethernet, offering maximum performance and enhanced capability for existing Ethernet-based networks.

100Mbps Fast Ethernet is a standard specified by the IEEE 802.3 LAN committee. It is an extension of the 10Mbps Ethernet standard with the ability to transmit and receive data at 100Mbps, while maintaining the CSMA/CD Ethernet protocol. Since the 100Mbps Fast Ethernet is compatible with all other 10Mbps Ethernet environments, it provides a straightforward upgrade path and takes advantage of the existing investment in hardware, software, and personnel training.

Switching Technology

Switching is a cost-effective way of increasing the total network capacity available to users on a LAN. If an Ethernet network begins to display symptoms of congestion, low throughput, slow response times, and high rates of collision, installing a switch to a network can preserve much or all of the existing network's cabling and workstation interface card infrastructure, while still greatly enhancing the throughput for users. A switch is a viable solution even if demanding applications, such as multimedia production and video conferencing, are on the horizon. The most promising techniques, as well as the best return on investment, could well consist of installing the right mixture of Ethernet switches.

A switch increases capacity and decreases network loading by dividing a local area network into different LAN segments. Dividing a LAN into multiple segments is one of the most common ways of increasing available bandwidth. If segmented correctly, most network traffic will remain within a single segment, enjoying the full-line speed bandwidth of that segment.

Switches provide full-line speed and dedicated bandwidth for all connections. This is in contrast to hubs, which use the traditional shared networking topology, where the connected nodes contend for the same network bandwidth. When two switching nodes are communicating, they are connected with a dedicated channel between them, so there is no contention for network bandwidth with other nodes. As a result, the switch reduces considerably, the likelihood of traffic congestion.

For Ethernet networks, a switch is an effective way of eliminating the problem of chaining hubs beyond the "two-repeater limit." A switch can be used to split parts of the network into different collision domains, making it possible to expand your Ethernet network beyond the 205-meter network diameter limit for 100BASE-TX networks. Switches supporting both 10Mbps Ethernet and 100Mbps Fast Ethernet are also ideal for bridging between existing 10Mbps networks and newer 100Mbps networks.

Switching LAN technology is a marked improvement over the previous generation of network hubs and bridges, which were characterized by higher latencies. Routers have also been used to segment local area networks, but the cost of a router, the setup and maintenance required, make routers relatively impractical. Today switches are an ideal solution for most kinds of local area network congestion problems.

Features

The DSS-8+ is a high performance switch designed specifically for environments where traffic on the network and the number of users increase continuously.

The DSS-8+, with its small, compact size, was specifically designed for small to mid-sized workgroups. The DSS-8+ can be installed where space is limited; moreover, it provides immediate access to a rapidly growing network through a wide range of user-reliable functions.

The DSS-8+ is ideal for deployment with multiple high-speed servers for 10Mbps or 100Mbps shared-bandwidth workgroups. With the highest bandwidth at 200Mbps (100Mbps full-duplex mode), any port can provide workstations with a congestion-free data pipe for simultaneous access to the server.

The DSS-8+ is scalable, allowing two or more DSS-8+s to be cascaded together. Since all ports support 200Mbps, any one of its eight ports may be used to cascade to an additional switch to open a Full-Duplex Fast Ethernet pipe.

The DSS-8+ is the perfect choice for a department or office planning to upgrade to Fast Ethernet. The DSS-8+ can accommodate 10Mbps or 100Mbps devices, providing a flexible solution for existing (10Mbps) Ethernet workgroups.

The DSS-8+ combines dynamic memory allocation with store-and-forward switching to ensure that the buffer is effectively allocated for each port; and it controls the data flow between the transmit and receive nodes to guarantee against possible packet loss.

The DSS-8+ is an unmanaged 10/100Mbps Fast Ethernet switch that offers solutions for the accelerating bandwidth needs of small Ethernet workgroups.

Other key features include:

- Store-and-forward switching scheme capability. As the result of complete frame checking and error frame filtering, this scheme prevents error packages from transmitting among segments.

- Auto-MDI/MDI-X. Detects the type of cable you are using, Crossover or Straight-Through, and automatically adjusts per port, allowing you to also use any port as an uplink port—the choice is yours. No more worries about whether you are using the right cable type or not. Auto MDI/MDI-X cable-type detection gives you true 'plug and play' capability.
- Nway Auto-negotiation for any port. This allows for auto-sensing of speed (10/100Mbps) and duplex mode (10/20/100/200Mbps), providing an automatic and flexible solution for the network.
- Flow control for any port. This minimizes dropped packets by sending out collision signals when the port's receiving buffer is full. Note that flow control is only available in half duplex mode.
- Data filtering rate eliminates all error packets, runts, etc., per port at wire-speed for 100Mbps operation and 10Mbps operation.

UNPACKING AND SETUP

Unpacking

Open the box and carefully unpack it. The box should contain the following items:

1. One DSS-8+ 8-port 10/100Mbps Ethernet Switch
2. One External Power Adapter
3. Four Rubber Feet
4. Nylon screw anchors and T3 x 15L screws
5. This Manual

If any item is missing or damaged, please contact your local reseller for a replacement.

Setup

The setup of the DSS-8+ can be performed using the following steps:

- The power outlet should be within 1.82 meters (6 feet) of the Switch.
- Visually inspect the DC power jack and make sure that it is fully secured to the power adapter.
- Do not cover the ventilation holes on the sides of the Switch, and make sure there is adequate ventilation around it.
- Do not place heavy objects on the switch.

IDENTIFYING EXTERNAL COMPONENTS

Front Panel

The figure below shows the front panel of the DSS-8+.

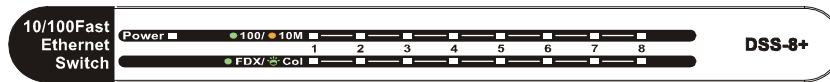

Front Panel LED Indicators

LED Indicators

- **Power Indicator**

This green indicator light is on when the DSS-8+ is receiving power; otherwise, it is off.

- **Full-Duplex/Collision Indicator (Full Duplex/Collision)**

This green indicator light is on when the port is in full-duplex (FDX) mode. Otherwise, it blinks as collisions occur on any port of the Switch.

- **100Mbps Link/Activity, 10Mbps Link/Activity Indicator (100 Link/Act (green), 10 Link/Act (amber))**

This LED indicator light is green when the port is connected to a 100Mbps Fast Ethernet station. The green indicator blinks as Fast Ethernet data is transmitted or received. The indicator light is amber when the port is connected to a 10Mbps Ethernet station, or other network device. The amber indicator blinks as Ethernet data is transmitted or received.

Rear Panel

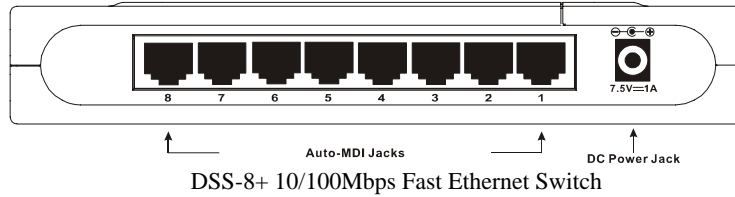

Auto MDI/MDI-X Ports:

All ports support automatic MDI/MDI-X cable-type detection, which eliminates the issue of choosing the right cable (Crossover or Straight-Through). The Auto MDI/MDI-X function makes it simple to connect to the Switch using either a Crossover or Straight-Through CAT5 cable into any port—the choice is yours.

DC Power Jack:

Power is supplied through an external DC power adapter. Check the technical specification section for information about the DC power input voltage.

Since the DSS-8+ does not include a power button, plugging its power adapter into a power outlet will immediately power it on.

CONNECTING THE DSS-8+

Computer to DSS-8+

A computer can be connected to the DSS-8+ via a two-pair Category 3, 4, 5 UTP/STP Straight-Through or Crossover cable. A computer equipped with a RJ-45 10/100Mbps port can be connected to any of the eight DSS-8+ ports.

The LED indicators for the computer connection depend on the capability of the computer's Ethernet card. If the LED indicators are not lit after making a proper connection, check the computer's Ethernet card, the cable, or the DSS-8+'s conditions and connections.

Hub to DSS-8+

A hub (10BASE-T or 100BASE-TX) can be connected to the DSS-8+ via a two-pair Category 3, 4, or 5 UTP/STP Straight-Through or Crossover cable. For 100Mbps operation a Category 5 cable **must** be used. The connection is accomplished from any port of the hub to any port of the DSS-8+.

DSS-8+ to other devices

The DSS-8+ can be connected to another switch or other devices (routers, bridges, etc.) via a two-pair Category 3, 4, 5 UTP/STP Straight-Through or Crossover cable. A Category 5 cable **must** be used for 100Mbps operation. The connection can be accomplished from any (MDI-X) port on the DSS-8+ to any of the 10Mbps or 100Mbps (MDI-X) ports on another switch or other devices.

Port Speed & Duplex Mode

After plugging the selected cable to a specific port, the system uses auto-negotiation to determine the transmission mode, auto-detecting the network speed (10Mbps or 100Mbps) for any new twisted-pair connection.

If the attached device **does not** support auto-negotiation or has auto-negotiation disabled, an auto-sensing process is initiated to select the speed and **half-duplex** mode is selected.

MOUNTING THE SWITCH ON A WALL

The DSS-8+ can also be mounted on a wall. Two mounting slots are provided on the bottom of the switch for this purpose. Please make sure that the front panel is exposed in order to view the LEDs. Please refer to the illustration below:

A.) Mounting on a cement wall

1. Mount the Nylon screw anchors into a cement wall.
2. Drive the T3 x 15L screws into the Nylon screw anchors.
3. Hook the mounting holes of the switch back on the screws; you have completed the wall-mount.

B.) Mounting on a wood wall

1. Drive the T3 x 15 L screws into the wood wall.
2. Hook the mounting holes of the switch back on the screws; you have completed the wall-mount.

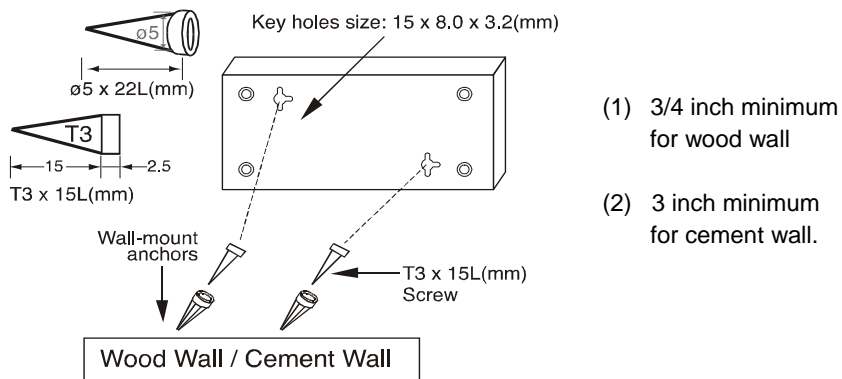

TECHNICAL SPECIFICATIONS

General	
Standards	IEEE 802.3 10BASE-T Ethernet IEEE 802.3u 100BASE-TX Fast Ethernet IEEE 802.3x Flow Control
Protocol	CSMA/CD
Data Transfer Rate	Ethernet: 10Mbps (half duplex), 20Mbps (full-duplex) Fast Ethernet: 100Mbps (half duplex), 200Mbps (full- duplex)
Topology	Star
Network Cables	10BASET: 2-pair UTP Cat. 3,4,5 (100 m), EIA/TIA- 568 100-ohm STP (100 m) 100BASE-TX: 2-pair UTP Cat. 5 (100 m), EIA/TIA-568 100-ohm STP (100 m)
Number of Ports	8 x 10/100Mbps auto-negotiation, auto MDI-X ports
Physical and Environmental	
DC inputs	DC 7.5V / 1A
Power Consumption	3.37 Watts (Max)
Temperature	Operating: 0° ~ 50° C (32° to 122° F), Storage: -10° ~ 70° C (14°to 158° F)
Humidity	Operating: 10% ~ 90%, Storage: 5% ~ 90%
Dimensions	192.5 x 118.5 x 32 mm (W x H x D) (approx. 7.5 x 4.5 x 1.25 inches)
EMI:	FCC Class B, CE Mark A, VCCI-II

Performance	
Transmission Method:	Store-and-forward
RAM Buffer	64 Kbytes per device
Filtering Address Table	1000 entries per device
Packet Filtering / Forwarding Rate:	10Mbps Ethernet: 14,880/pps 100Mbps Fast Ethernet: 148,800/pps
MAC Address Learning:	Automatic update

RJ-45 PIN SPECIFICATION

The following diagram and tables show the standard RJ-45 receptacle/connector and their pin assignments.

RJ-45 Connector pin assignment	
Contact	Medium-Direct Interface Signal
1	Tx + (transmit)
2	Tx - (transmit)
3	Rx + (receive)
4	Not used
5	Not used
6	Rx - (receive)
7	Not used
8	Not used

RJ-45 pin assignment

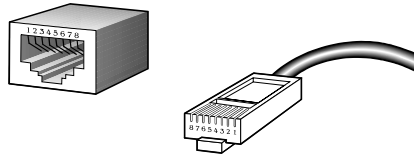

Standard RJ-45 receptacle/connector

WARRANTY

Subject to the terms and conditions set forth herein, D-Link Systems, Inc. ("D-Link") provides this Limited warranty for its product only to the person or entity that originally purchased the product from:

- D-Link or its authorized reseller or distributor and
- Products purchased and delivered within the fifty states of the United States, the District of Columbia, U.S. Possessions or Protectorates, U.S. Military Installations, addresses with an APO or FPO.

Limited Warranty: D-Link warrants that the hardware portion of the D-Link products described below will be free from material defects in workmanship and materials from the date of original retail purchase of the product, for the period set forth below applicable to the product type ("Warranty Period"), except as otherwise stated herein.

5-Year Limited Warranty for the Product(s) is defined as follows:

- Hardware (excluding power supplies and fans) Five (5) Years
- Power Supplies and Fans Three (3) Year
- Spare parts and spare kits Ninety (90) days

D-Link's sole obligation shall be to repair or replace the defective Hardware during the Warranty Period at no charge to the original owner or to refund at D-Link's sole discretion. Such repair or replacement will be rendered by D-Link at an Authorized D-Link Service Office. The replacement Hardware need not be new or have an identical make, model or part. D-Link may in its sole discretion replace the defective Hardware (or any part thereof) with any reconditioned product that D-Link reasonably determines is substantially equivalent (or superior) in all material respects to the defective Hardware. Repaired or replacement Hardware will be warranted for the remainder of the original Warranty Period from the date of original retail purchase. If a material defect is incapable of correction, or if D-Link determines in its sole discretion that it is not practical to repair or replace the defective Hardware, the price paid by the original purchaser for the defective Hardware will be refunded by D-Link upon return to D-Link of the defective Hardware. All Hardware (or part thereof) that is replaced by D-Link, or for which the purchase price is refunded, shall become the property of D-Link upon replacement or refund.

Limited Software Warranty: D-Link warrants that the software portion of the product ("Software") will substantially conform to D-Link's then current functional specifications for the Software, as set forth in the applicable documentation, from the date of original retail purchase of the Software for a period of ninety (90) days ("Warranty Period"), provided that the Software is properly installed on approved hardware and operated as contemplated in its documentation. D-Link further warrants that, during the Warranty Period, the magnetic media on which D-Link delivers the Software will be free of physical defects. D-Link's sole obligation shall be to replace the non-conforming Software (or defective media) with software that substantially conforms to D-Link's functional specifications for the Software or to refund at D-Link's sole discretion. Except as otherwise agreed by D-Link in writing, the replacement Software is provided only to the original licensee, and is subject to the terms and conditions of the license granted by D-Link for the Software. Software

will be warranted for the remainder of the original Warranty Period from the date of original retail purchase. If a material non-conformance is incapable of correction, or if D-Link determines in its sole discretion that it is not practical to replace the non-conforming Software, the price paid by the original licensee for the non-conforming Software will be refunded by D-Link; provided that the non-conforming Software (and all copies thereof) is first returned to D-Link. The license granted respecting any Software for which a refund is given automatically terminates.

Non-Applicability of Warranty: The Limited Warranty provided hereunder for hardware and software of D-Link's products, will not be applied to and does not cover any product purchased through the inventory clearance or liquidation sale or other sales in which D-Link, the sellers, or the liquidators expressly disclaim their warranty obligation pertaining to the product and in that case, the product is being sold "As-Is" without any warranty whatsoever including, without limitation, the Limited Warranty as described herein, notwithstanding anything stated herein to the contrary.

Submitting A Claim: Any claim under this limited warranty must be submitted in writing before the end of the Warranty Period to an Authorized D-Link Service Office.

- The customer must submit as part of the claim a written description of the Hardware defect or Software nonconformance in sufficient detail to allow D-Link to confirm the same.
- The original product owner must obtain a Return Material Authorization ("RMA") number from the Authorized D-Link Service Office and, if requested, provide written proof of purchase of the product (such as a copy of the dated purchase invoice for the product) before the warranty service is provided.
- After an RMA number is issued, the defective product must be packaged securely in the original or other suitable shipping package to ensure that it will not be damaged in transit, and the RMA number must be prominently marked on the outside of the package. Do not include any manuals or accessories in the shipping package. D-Link will only replace the defective portion of the Product and will not ship back any accessories.
- The customer is responsible for all shipping charges to D-Link. No Charge on Delivery ("COD") is allowed. Products sent COD will either be rejected by D-Link or become the property of D-Link. Products should be fully insured by the customer and shipped to **D-Link Systems, Inc., 17595 Mt. Herrmann Street, Fountain Valley, CA 92708**. D-Link will not be held responsible for any packages that are lost in transit to D-Link. The repaired or replaced packages will be shipped via UPS Ground or any common carrier selected by D-Link, with shipping charges prepaid. Expedited shipping is available if shipping charges are prepaid by the customer.

D-Link may reject or return any product that is not packaged and shipped in strict compliance with the foregoing requirements, or for which an RMA number is not visible from the outside of the package. The product owner agrees to pay D-Link's reasonable handling and return shipping charges for any product that is not packaged and shipped in accordance with the foregoing requirements, or that is determined by D-Link not to be defective or non-conforming.

What Is Not Covered: This limited warranty provided by D-Link does not cover: Products, if in D-Link's judgment, have been subjected to abuse, accident, alteration, modification, tampering, negligence, misuse, faulty installation, lack of reasonable care, repair or service in any way that is not contemplated in the documentation for

the product, or if the model or serial number has been altered, tampered with, defaced or removed; Initial installation, installation and removal of the product for repair, and shipping costs; Operational adjustments covered in the operating manual for the product, and normal maintenance; Damage that occurs in shipment, due to act of God, failures due to power surge, and cosmetic damage; Any hardware, software, firmware or other products or services provided by anyone other than D-Link; Products that have been purchased from inventory clearance or liquidation sales or other sales in which D-Link, the sellers, or the liquidators expressly disclaim their warranty obligation pertaining to the product. Repair by anyone other than D-Link or an Authorized D-Link Service Office will void this Warranty.

Disclaimer of Other Warranties: EXCEPT FOR THE LIMITED WARRANTY SPECIFIED HEREIN, THE PRODUCT IS PROVIDED "AS-IS" WITHOUT ANY WARRANTY OF ANY KIND WHATSOEVER INCLUDING, WITHOUT LIMITATION, ANY WARRANTY OF MERCHANTABILITY, FITNESS FOR A PARTICULAR PURPOSE AND NON-INFRINGEMENT. IF ANY IMPLIED WARRANTY CANNOT BE DISCLAIMED IN ANY TERRITORY WHERE A PRODUCT IS SOLD, THE DURATION OF SUCH IMPLIED WARRANTY SHALL BE LIMITED TO NINETY (90) DAYS. EXCEPT AS EXPRESSLY COVERED UNDER THE LIMITED WARRANTY PROVIDED HEREIN, THE ENTIRE RISK AS TO THE QUALITY, SELECTION AND PERFORMANCE OF THE PRODUCT IS WITH THE PURCHASER OF THE PRODUCT.

Limitation of Liability: TO THE MAXIMUM EXTENT PERMITTED BY LAW, D-LINK IS NOT LIABLE UNDER ANY CONTRACT, NEGLIGENCE, STRICT LIABILITY OR OTHER LEGAL OR EQUITABLE THEORY FOR ANY LOSS OF USE OF THE PRODUCT, INCONVENIENCE OR DAMAGES OF ANY CHARACTER, WHETHER DIRECT, SPECIAL, INCIDENTAL OR CONSEQUENTIAL (INCLUDING, BUT NOT LIMITED TO, DAMAGES FOR LOSS OF GOODWILL, LOSS OF REVENUE OR PROFIT, WORK STOPPAGE, COMPUTER FAILURE OR MALFUNCTION, FAILURE OF OTHER EQUIPMENT OR COMPUTER PROGRAMS TO WHICH D-LINK'S PRODUCT IS CONNECTED WITH, LOSS OF INFORMATION OR DATA CONTAINED IN, STORED ON, OR INTEGRATED WITH ANY PRODUCT RETURNED TO D-LINK FOR WARRANTY SERVICE) RESULTING FROM THE USE OF THE PRODUCT, RELATING TO WARRANTY SERVICE, OR ARISING OUT OF ANY BREACH OF THIS LIMITED WARRANTY, EVEN IF D-LINK HAS BEEN ADVISED OF THE POSSIBILITY OF SUCH DAMAGES. THE SOLE REMEDY FOR A BREACH OF THE FOREGOING LIMITED WARRANTY IS REPAIR, REPLACEMENT OR REFUND OF THE DEFECTIVE OR NON-CONFORMING PRODUCT. THE MAXIMUM LIABILITY OF D-LINK UNDER THIS WARRANTY IS LIMITED TO THE PURCHASE PRICE OF THE PRODUCT COVERED BY THE WARRANTY. THE FOREGOING EXPRESS WRITTEN WARRANTIES AND REMEDIES ARE EXCLUSIVE AND ARE IN LIEU OF ANY OTHER WARRANTIES OR REMEDIES, EXPRESS, IMPLIED OR STATUTORY

Governing Law: This Limited Warranty shall be governed by the laws of the state of California. Some states do not allow exclusion or limitation of incidental or consequential damages, or limitations on how long an implied warranty lasts, so the foregoing limitations and exclusions may not apply. This limited warranty provides specific legal rights and the product owner may also have other rights which vary from state to state.

Trademarks: D-Link is a registered trademark of D-Link Systems, Inc. Other trademarks or registered trademarks are the property of their respective

manufacturers or owners.

Copyright Statement: No part of this publication or documentation accompanying this Product may be reproduced in any form or by any means or used to make any derivative such as translation, transformation, or adaptation without permission from D-Link Corporation/D-Link Systems, Inc., as stipulated by the United States Copyright Act of 1976. Contents are subject to change without prior notice. Copyright © 2002 by D-Link Corporation/D-Link Systems, Inc. All rights reserved.

CE Mark Warning: This is a Class B product. In a domestic environment, this product may cause radio interference, in which case the user may be required to take adequate measures.

FCC Statement: This equipment has been tested and found to comply with the limits for a Class B digital device, pursuant to part 15 of the FCC Rules. These limits are designed to provide reasonable protection against harmful interference in a residential installation. This equipment generates uses and can radiate radio frequency energy and, if not installed and used in accordance with the instructions, may cause harmful interference to radio communication. However, there is no guarantee that interference will not occur in a particular installation. If this equipment does cause harmful interference to radio or television reception, which can be determined by turning the equipment off and on, the user is encouraged to try to correct the interference by one or more of the following measures:

- Reorient or relocate the receiving antenna.
- Increase the separation between the equipment and receiver.
- Connect the equipment into an outlet on a circuit different from that to which the receiver is connected.
- Consult the dealer or an experienced radio/TV technician for help.

REGISTRATION

Register your product on-line at:
<http://support.dlink.com/register>

Product registration is entirely voluntary and failure to complete or return this form will not diminish your warranty rights.

TECHNICAL SUPPORT

Technical Support

You can find software updates and user documentation on the D-Link website.

D-Link provides free technical support for customers within the United States and within Canada for the duration of the warranty period on this product.

U.S. and Canadian customers can contact D-Link technical support through our website, or by phone.

Tech Support for customers within the United States:

D-Link Technical Support over the Telephone:

(877) 453-5465

24 hours a day, seven days a week.

D-Link Technical Support over the Internet:

<http://support.dlink.com>

email:support@dlink.com

Tech Support for customers within Canada:

D-Link Technical Support over the Telephone:

(800) 361-5265

Monday to Friday 8:30am to 9:00pm EST

D-Link Technical Support over the Internet:

<http://support.dlink.ca>

email:support@dlink.ca

P/N:1907DS1008*6006